

# WILL SERVANT LEADERSHIP AFFECT EMPLOYEE ENGAGEMENT AND QUALITY OF SERVICE DELIVERY?

Waiphot Kulachai<sup>1</sup>  
Layla Kurniawati  
Patipol Homyamyen  
Pennapa Pornsupikul  
Thaywuse Borriraksuntikul

Received 26.06.2023.  
Accepted 15.11.2023.  
UDC – 005.6

## Keywords:

*Servant Leadership, Employee  
Engagement, Quality of Service  
Delivery*



## ABSTRACT

*This paper aimed to examine the relationship between servant leadership, employee engagement, and quality of service delivery. For this purpose, a structural equation modeling with AMOS was used to test the model fit and the relationship between each latent variable. Findings reveal that the model was fit with the empirical data. Servant leadership had a positive impact on employee engagement mediating the association between servant leadership and quality of service delivery. However, servant leadership had a negative impact on the quality of service delivery. In addition, the findings reveal a positive relationship between employee engagement and quality of service delivery. Relevant implications for future studies in this area are discussed.*

© 2023 Published by Faculty of Engineering

## 1. INTRODUCTION

The leadership of executives in the organization is considered critical to organizational success because if the organization has executives with good leadership, they can convince and motivate employees to put their physical and mental effort into fully performing their tasks. Therefore, organizations need executives with high leadership and the strength to lead the organization to be as effective as possible. Leaders must be able to change the current state of the organization and create a vision for the future of the organization, including inspiring employees to lead the organization to achieve the vision set forth. In addition, leaders must have the

ability to formulate plans, optimize organizational structure and take good care of employee performance (Robbins & Judge, 2017). However, there is still debate in academic circles about what leadership styles can lead the organization to achieve its goals effectively.

At present, servant leadership has received a steady increase in the attention of scholars and practitioners because there is a pattern of how to lead others by serving others first (Carter & Baghurst, 2014). In addition, servant leaders do not look primarily at their own interests, but they seek to create opportunities to help subordinates thrive and progress (Robbins & Judge, 2017).

<sup>1</sup> Corresponding author: Waiphot Kulachai  
Email: [waiphot.ku@ssru.ac.th](mailto:waiphot.ku@ssru.ac.th)

Some scholars are interested in whether the theory of servant leadership has a unique character that differs from traditional concepts as well as whether it values and promotes organizational growth and success of the organization? (Parris & Peachey, 2013, Farah 2023)). In recent times, scholars have paid attention to the elements of servant leadership. Daft (1999) explains that the attributes of a servant leader consist of 5 key elements. These include service before self, listening as a means of affirmation, creating trust, and nurturing followers to become whole. Liden, Wayne, Zhao, and Henderson (2008) studied the seven elements of servant leadership including emotional healing, creating value for the community, conceptual skills, empowering, helping subordinates grow and succeed, putting subordinates first, and behaving ethically. Meanwhile, Mittal and Dorfman (2012) discovered five key elements of servant leadership including egalitarianism, moral integrity, empowering, empathy, and humility. In a study on the elements of servant leadership in Thailand, it has been found that there are eight important elements, such as agapao love, humility, altruistic, vision, trust, empowerment, service, and awareness (Chantaradecha et al., 2014).

In addition to the issue of studying the elements of servant leadership, some scholars have studied the impact of servant leadership from several perspectives, such as Meemoei, Jongwisai, and Sakdiworapong (2011) studied the relationship between servant leadership and the performance of junior executives. Rasheed and Lodhi (2015) examined the relationship between servant leadership and the creative behavior of employees being mediated by employee engagement that encourages employees to have higher levels of creative behavior. Dannhauser and Boshoff (2006) studied the relationship between servant leadership and team trust and engagement while some scholars studied the relationship between servant leadership and service delivery quality, as well as motivation for service delivery (Jaramillo et al., 2009; Hunter et al., 2013; Liu, Hu, & Cheng, 2015). Some studied the relationship between servant leadership and employee trust in organizations and supervisors (Chinomona, Mashiloane, & Poee, 2013; Dannhauser & Boshoff, 2006). Furthermore, the impact of servant leadership on employee engagement was also examined (Carter & Baghurst, 2014; Pipitvej, 2014); Rayan, Wong, & Bañas, 2015).

Based on a review of recent research, it has been shown that servant leadership has a positive effect on many organizations because it encourages employees to perform well (Awan, Qureshi, & Arif, 2012), have a better service mind and work for customer service (Jaramillo et al., 2009; Hunter et al., 2013; Liu, Hu, & Cheng, 2015; Ling, Lin, & Wu, 2016). It also encourages employees to be creative (Yoshida et al., 2014; Rasheed & Lodhi, 2015; Jaiswal & Dhar, 2017, Minh Tri 2023), are engaged to work (Chinomona, Mashiloane, & Poee, 2013; Carter & Baghurst, 2014;

Rayan, Wong, & Bañas, 2015; Sousa & van Dierendonck, 2015; Harwiki, 2016), and also trust to supervisors or colleagues (Dannhauser & Boshoff, 2006; Chatbury, Beaty, & Kriek, 2011; Chinomona, Mashiloane, & Poee, 2013; Jaiswal & Dhar, 2017). This also contributes to a better working atmosphere and promotes good relations between people in the organization. For this reason, the authors are interested in studying the impact of servant leadership on the quality of service provided by government agencies, as government agencies are the main agencies that must provide public services to people at all levels and sectors. The impact of servant leadership on employee engagement is also examined in the present study.

## 2. SERVANT LEADERSHIP

Servant leadership (servant leadership) It is a leadership model initiated by Greenleaf (Anzalone, 2007) Former company executive at AT&T limited. It was inspired by the novel "Journey to the East" Authored by Hesse. He mentioned servant leadership as:

*"The servant leader is servant first ... It begins with the natural feeling that one wants to serve. ... Then conscious choice brings one to aspire to lead. That person is sharply different from one who is a leader first, perhaps because of the need to assuage an unusual power drive or to acquire material possessions. ..."*

Scholars define servant leadership differently in their own research. Bass (2000) defined servant leadership that it involves encouraging subordinates to learn, grow and have freedom of work. Page and Wong (2002) explained that servant leadership may refer to leaders whose main aim is to serve others by investing in improving the well-being of those employees so they are able to complete their tasks and achieve their goals. In addition, Reinke (2004) gives the meaning of servant leadership as referring to individuals who are dedicated to creating growth for both employees and the organization. Moreover, it is also a person who works to build a good community within the organization. In this study, the authors defined servant leadership as a person who has the heart to serve others, especially the emphasis on subordinates, and doing his/her best to encourage and support subordinates to succeed in both their professional lives and well-being.

From a review of the literature dealing with the components of servant leadership, they can be summarized as shown in Table 1.

**Table 1.** Elements of servant leadership

Authors	Elements
Daft (1999)	1. Service before self 2. Listening as a means of affirmation 3. Creating trust 4. Nourishing followers to become whole

Laub (1999)	<ol style="list-style-type: none"> <li>1. Values people</li> <li>2. Develops people</li> <li>3. Building community</li> <li>4. Displays authenticity</li> <li>5. Provides leadership</li> <li>6. Shares leadership</li> </ol>
Russell & Stone (2002)	<ol style="list-style-type: none"> <li>1. Vision</li> <li>2. Honesty</li> <li>3. Integrity</li> <li>4. Trust</li> <li>5. Service</li> <li>6. Modeling</li> <li>7. Pioneer</li> <li>8. Appreciation of others</li> <li>9. Empowerment</li> </ol>
Spears (2004)	<ol style="list-style-type: none"> <li>1. Listening</li> <li>2. Empathy</li> <li>3. Healing</li> <li>4. Awareness</li> <li>5. Persuasion</li> <li>6. Conceptualization</li> <li>7. Foresight</li> <li>8. Stewardship</li> <li>9. Commitment to the growth of people</li> <li>10. Building community</li> </ol>
Barbuto & Wheeler (2006)	<ol style="list-style-type: none"> <li>1. Altruist valuing</li> <li>2. Emotional healing</li> <li>3. Persuasive mapping</li> <li>4. Wisdom</li> <li>5. Organizational stewardship</li> </ol>
Liden, Wayne, Zhao, & Henderson (2008)	<ol style="list-style-type: none"> <li>1. Emotional healing</li> <li>2. Creating value for the community</li> <li>3. Conceptual skills</li> <li>4. Empowering</li> <li>5. Helping subordinates grow and succeed</li> <li>6. Putting subordinates first</li> <li>7. Behaving ethically</li> </ol>
Reed, Vidaver-Cohen, & Colwell (2011)	<ol style="list-style-type: none"> <li>1. Interpersonal support</li> <li>2. Building community</li> <li>3. Altruism</li> <li>4. Egalitarianism</li> <li>5. Moral integrity</li> </ol>
van Dierendonck (2011)	<ol style="list-style-type: none"> <li>1. Empowerment</li> <li>2. Humility</li> <li>3. Standing back</li> <li>4. Stewardship</li> <li>5. Authenticity</li> </ol>
Mittal & Dorfman (2012)	<ol style="list-style-type: none"> <li>1. Egalitarianism</li> <li>2. Moral integrity</li> <li>3. Empowering</li> <li>4. Empathy</li> <li>5. Humility</li> </ol>
Focht & Ponton (2015)	<ol style="list-style-type: none"> <li>1. Valuing people</li> <li>2. Humility</li> <li>3. Listening</li> <li>4. Trust</li> <li>5. Caring</li> <li>6. Integrity</li> <li>7. Service</li> <li>8. Empowering</li> <li>9. Serving others needs before their own</li> <li>10. Collaboration</li> </ol>

This present study adopted the five elements of servant leadership as suggested by van Dierendonck (2011) including empowerment, humility, standing back, stewardship, and authenticity.

### 3. EMPLOYEE ENGAGEMENT AND SERVANT LEADERSHIP

Employee engagement plays a huge part in the organization because it is dedicated to leading the organization to progress and achieve its goals. The term employee commitment is different from employee engagement because employee engagement focuses on working according to the responsible role while organizational commitment is primarily focused on attitudes or attachment to the organization. Gubman (1998) explains that employee engagement means: Dedication and energy to working for the organization with creative ways of working and results exceeding expectations. Carter and Baghurst (2014) explain that employee engagement means employees show their love for the job and the organization they work in. This is reflected in the commitment and dedication to working for the organization to succeed. Employee engagement, therefore, has to do with providing good service to customers as well as protecting their organization. In summary, employee engagement refers to an employee's attitude towards the organization that gives the employee a sense of dedication to working for the organization to the best of their ability, protecting the organization, trying to achieve the organization's goals, as well as having shared values and goals with other members of the organization. For this reason, employee engagement of police has to do with providing good services to citizens, as well as protecting their own organizations.

Soane et al. (2012) divided employee engagement into three categories: intellectual engagement, social engagement, and affective engagement. Intellectual engagement refers to the degree to which a person is intellectually absorbed in their work and thinks of ways to work to improve their work. Social engagement is related to the degree to which a person has social connections with colleagues and their environment, as well as having shared values with colleagues in the organization. Finally, affective engagement refers to the degree to which a person has positive emotional experiences related to their role in their work.

Measuring employee engagement is sensitive because the context of each organization, country, and region is different. According to the review of the literature, there are six interesting scales. First, Utrecht Work Engagement Scale (UWES). It is developed by Schaufeli and Bakker (2003), this scale consists of three dimensions: vigor, dedication, and absorption. The vigor consists of six items related to the degree of vitality at work, high dedication to the job, fatigue from difficult work, diligence, and patience in solving

problems and difficulties in the work. The dedication dimension consists of five items related to feeling important, enthusiastic, proud, motivated, and challenged in the work they do. The absorption dimension consists of six items, such as "while I was working, I feel like time has passed quickly." "While I was working, I would forget everything around me," and "I feel happy when I'm fully engaged," Second, the IES Engagement Scale. It is a measure of employee engagement developed by The Institute for Employment Studies (IES), with Robinson et al. (2007) as the mainstay in its development. Initially, the scale consisted of twelve items, but the researchers determined that if the questionnaire was longer, the respondents would not want to provide information. Therefore, it has been reduced to only five items related to having a positive attitude towards the organization and being proud of the organization, trust in the organization, two-way relationships, selflessness, and high dedication to the organization. Third, the Shirom Melamed Vigor Measure (SMVM). It is developed by Shirom (2004), this scale consists of three dimensions: physical strength, emotional energy, and cognitive liveliness. The physical strength dimension consists of five items. The emotional energy dimension consists of four items whereas the cognitive liveliness dimension consists of five items. Fourth, Saks's Employee Engagement Scale. It consists of two parts: job engagement and organizational engagement. Both job engagement and organizational engagement scales consist of six items. Fifth, Job Engagement Scale (JES). This scale was developed by Rich, LePine, and Crawford (2010). The scale consists of three dimensions: physical engagement, emotional engagement, and cognitive engagement, each with six items. Finally, the ISA Engagement Scale. This scale was developed by Soane et al. (2012), based on the concepts of Kahn's (1990) concept. It initially consisted of twenty-one items: 8 cognitive engagements, 8 social engagements, and 5 affective engagements. Later, the three dimensions were developed into three items each. In this present study, the authors adopted the ISA Engagement Scale to measure employee engagement.

There are various factors influencing employee engagement. According to a study by Chinomona and Chinomona (2013), perceptions of organizational politics have a negative influence on corporate affiliation. It shows that if employees have a high awareness of organizational politics, there will be a decrease in affiliation with the organization. Wong and Laschinger (2015) found that job stress is a contributing factor to job fatigue that reduces employee engagement with the organization. Khatibi, Asadi, and Hamidi (2009) stated that job stress is negatively correlated with employee engagement with the organization. If employees have high job stress, there will be a decrease in engagement with the organization.

Servant leadership is also an important factor affecting employee engagement. A study by Keith (2008) found that servant leader will take care of employees' needs and helps build the confidence of employees. These will enhance employee, who has to connect directly with the customer, to provide good service to the customer, which ultimately directly affects the future of the organization in the long run. A study by Carter and Baghurst (2014) also found similar findings. It revealed that servant leadership helps build a culture of dedicated work as well as helps build strong working relationships between people in the organization. Servant leadership also affects employee engagement, which contributes to a better overall performance of the organization. The findings are consistent with other previous studies (Pipitvej, 2014; Rayan, Wong, & Bañas, 2015). Hence, the first hypothesis was:

*H1: Servant leadership has a positive impact on employee engagement.*

#### **4. QUALITY OF SERVICE DELIVERY AND SERVANT LEADERSHIP**

The provision of government services is extremely important in caring for and meeting the needs of the people. If the government allocates quality services that are in line with the needs of the people, this will allow people to live in society peacefully. On the other hand, if the government allocates non-quality services to the people, it will cause people to be less satisfied with the administration of the public sector and may lead to protests that can cause chaos later on. For example, the police service is a service for the safety of people's lives and property. When the crime occurs and police officers can quickly arrest offenders, it will satisfy the public, but if there are many crimes committed in society and police officers cannot arrest the perpetrators for prosecution, it will cause public panic and eventually a lack of trust in the police organization.

Parasuraman et al. (1988) explained that service quality refers to an organization's ability to provide services that meet the needs of the customer or exceed the expectation of the customer. Therefore, quality-of-service delivery by a public organization means providing services that are in accordance with the needs of the people or exceed expectations of the people. Several scholars proposed scales to measure the quality of service delivery as shown in Table 2.

The quality of service delivery is influenced by various factors. For example, employee potential, technology, communications, and budget (Wanjau, Muiruri, & Ayodo, 2012; Musyoka, Ochieng, & Ozioki, 2016;), training Zumrah (2014), Creative activities (Salge & Vera (2012), and servant leadership (Jaramillo et al., 2009; Hunter et al., 2013; Liu, Hu, & Cheng, 2015; Ling, Lin, & Wu, 2016). In this present study, the authors focused mainly on the relationship between

servant leadership and quality of service delivery. Hence, the second hypothesis was:

*H2: Servant leadership has a positive impact on the quality of service delivery.*

**Table 2.** Quality of service delivery scales

Authors	Scale	Elements
Parasurman et al. (1988)	SERVQUAL	1. Reliability 2. Responsiveness 3. Assurance 4. Empathy 5. Tangibles
Cronin & Taylor (1992)	SERVPERF	1. Expectation 2. Performance 3. Importance 4. Future purchase behavior 5. Overall quality 6. Satisfaction
Rust & Oliver (1994)	No specific name	1. Service product 2. Service delivery 3. Service environment

## 5. EMPLOYEE ENGAGEMENT AND QUALITY OF SERVICE DELIVERY

Employee engagement leads to positive results for not only employees but also the organization. It can enhance organizational success, (Sarangi & Nayak, 2018), productivity (George, Supramaniam, & Arumugam, 2021), and organizational performance (Muller, Smith, & Lillah, 2018; Shrestha, 2019), job satisfaction (Sungmala, 2021), organizational commitment (Sungmala, 2021), and job performance (Almawali, Hafit, & Hassan, 2021). Most literature focuses on private organizations. Also, few studies examined the association between employee engagement and the police's quality of service delivery. Ngumbao and Muturi (2018) conducted research entitled "Influence of employee engagement strategies on service delivery in Nairobi City County, Kenya." They found a positive relationship between these two variables. Wushe and Shenje (2019) conducted a study entitled "The antecedents of employee engagement and their effect on public sector service delivery: The case study of government departments in Harare." They found that employee engagement positively impacted service delivery in the public sector. Hence, the third hypothesis was:

*H3: Employee engagement has a positive impact on the quality-of-service delivery.*

## 6. METHODS

### 6.1 Sample

The data for this study were collected from police officers attending training courses at the Police Education Bureau, the Royal Thai Police. The

researchers used simple random sampling to draw samples. The researchers used the G\*Power software application to calculate the sample size and power for statistical methods from the whole population of 846 police officers (Faul et al., 2007). The calculations employed a medium effect size of 0.3 and the power of the test of .80 with an alpha of .05, resulting in a total sample size of 433. Ten research assistants were trained to properly administer the questionnaire to police officers at the Police Education Bureau. The research assistants learned to inform each sample of (1) the research purposes, (2) the study's benefits and anonymity, (3) his/her right to refuse and/or withdraw from participating in the survey, and (4) the time frame for the survey.

Each participant also gave consent before completing the questionnaire. After a month of the data collection process (August 2020), 500 police officers participated in the survey questionnaire and 489 questionnaires were completed. The demographic characteristics of the sample are summarized in Table 3.

**Table 3.** Characteristics of the samples (N=489)

Characteristics	Frequency	Percentage
Gender		
Male	370	75.66
Female	119	24.34
Marital status		
Single	91	18.61
Married	361	73.82
Widowed	9	1.84
Divorced	25	5.11
Others	3	0.61
Education		
Secondary school or lower	2	0.41
High school or equivalent	16	3.27
High vocational school or equivalent	4	0.82
Bachelor's degree	304	62.17
Master's degree or higher	163	33.33
Position		
Sub-inspector	413	84.46
Inspector/ Deputy superintendent	73	14.93
Superintendent and higher	3	0.61
Job type		
Traffic	16	3.27
Investigation	166	33.95
Suppression	109	22.29
General affairs	195	39.88
Others	3	0.61
Other characteristics	Mean	S.D.
Age	46.97	6.65
Tenure	23.87	7.65
Income*	33,277.61	7,711.53

1THB = 0.030278349 USD

## 6.2 Measurement

### 6.2.1 Exogenous Latent Variable

Servant leadership (SL) was an exogenous variable composed of five dimensions with 18 items, namely empowerment (EMP = 6 items), humility (HUM = 3 items), standing back (STA = 3 items), stewardship (STE = 3 items), and authenticity (AUT = 3 items). The respondents were asked to rate their perceived level of servant leadership in each question from 1 to 5, with 1 representing strongly disagree and 5 representing strongly agree. Some questions regarding servant leadership were (1) my superiors are there to help me improve myself; (2) my superiors learn new things from other people's advice; and (3) my superiors express sincere feelings towards their subordinates. The measurement provided an alpha reliability of .884.

### 6.2.2 Endogenous Latent Variables

Employee engagement (EE) was an endogenous variable. It is measured using ISA Engagement Scale developed by Soane et al. (2012). The scale is divided into 3 dimensions: intellectual engagement (IE = 3 items), social engagement (SE = 3 items), and affective engagement (AE = 3 items). The respondents were asked to rate their perceived level of servant leadership in each question from 1 to 5, with 1 representing strongly disagree and 5 representing strongly agree. Some questions regarding employee engagement were (1) I work hard; (2) I have the same work values as my colleagues; and (3) I have a good attitude toward my job. The measurement provided an alpha reliability of .844. Quality of service delivery (QOSD) is an endogenous variable. It was measured using the SERVQUAL scale developed by Parasurman et al. (1988). It is divided into five dimensions: reliability (REL = 4 items), responsiveness (RES = 4 items), assurance (ASS = 4 items), empathy (EMPA = 4 items), and tangibles (TAN = 4 items). Originally, it has 22 items but the authors adopted only 20 items. Some questions regarding employee engagement were (1) I express a sincere interest in solving problems for the people; (2) I provide services to the people in a timely and prompt manner; and (3) I can serve the people with purity and fairness. The measurement provided an alpha reliability of .925.

## 6.3 Analysis

The data were analyzed using the structural equation modeling (SEM) technique. This is a multivariate statistical analysis technique that is used to analyze structural relationships. This technique is a combination of factor analysis and multiple regression analysis, and it is used to analyze the structural relationship between measured variables and latent constructs. The present study employed an index of statistical values that are used to examine and show whether the model is fitted with the empirical data. It consists of p-value > .05,

$\chi^2/df < 2$ , GFI > 0.95, NFI > 0.95, CFI > 0.95, RMSEA < 0.05 (Hair, Back, Babin, & Anderson, 2010; Suksawang, 2013).

## 7. RESULTS

### 7.1 Descriptive Statistics and Correlations

Table 4, presents descriptive statistics and inter-correlations among the variables of the study. The means and standard deviations were within reasonable limits. The inter-correlations among variables were also reasonable and provided additional affirmation for the construct validity of our measures. In all but two cases Pearson's r was lower or equal to 0.50 but still far from the 0.80 level, which may indicate a problem of multicollinearity.

**Table 4.** Descriptive statistics and inter-correlations between variables

Variable	Mean	S.D.	SL	EE	QOSD
SL	4.52	1.11	-		
EE	4.02	.63	.42**	-	
QOSD	4.06	.56	.29**	.74**	-

\*\*Correlation is significant at the 0.01 level (2-tailed).

### 7.2 Goodness of Fit

The results reveal the model chi-square of 272.634 with 62 degrees of freedom. The p-value is significant ( $p < .05$ ). The values of GFI and RMSEA, the absolute fit index, are 0.918 and 0.083 in that order. These values indicate the model does not fit with the empirical data. The normed chi-square is 4.397 which is over 2.00, indicating unfit for the hypothesized model. According to the incremental fit indices, the CFI, an incremental fit index, has a value of 0.962, which exceeds the suggested cut-off values. In addition, the AGFI, a parsimony fit index, has a value of 0.880, which reflects an unfit model as shown in Figure 1.

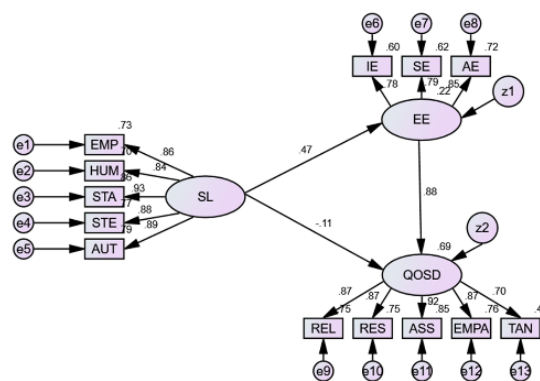

Chi-square = 272.634, df = 62, Chi-square/df = 4.397, p = .000, GFI = .918, AGFI = .880, CFI = .962, RMSEA = .083, RMR = .036, NFI = .951

**Figure 1.** Hypothesized model

The researchers revised the model in accordance with the modification indices as suggested by the software.



The revised model shows the model chi-square of 166.314 with 56degrees of freedom. The *p*-value is significant (*p*<.05). Hair et al. (2010) suggested that the significance of the *p*-value is expected if the sample size is greater than 250 and the number of observed variables is greater than 12 but does not exceed 30. The values of GFI and RMSEA, the absolute fit index, are 0.951 and 0.064 in that order. These values indicate the model fits with the empirical data. Although there is no consensus regarding an acceptable ratio for this statistic, recommendations range from as high as 5.0 (Wheaton et al., 1977) to as low as 2.0 (Tabachnick & Fidell, 2007). The present study found that the normed chi-square is 2.970, indicating fit for the revised model. According to the incremental fit indices, the CFI, an incremental fit index, has a value of 0.980, which exceeds the suggested cut-off values. In addition, the AGFI, a parsimony fit index, has a value of 0.920, which reflects a fit model according to Hooper, Coughlan, and Mullen (2008). All information on goodness-of-fit statistics is illustrated in Figure 2 and Table 5.

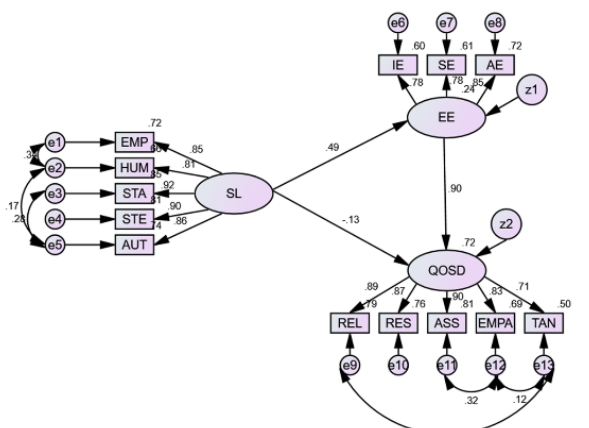

Chi-square = 166.314, df = 56, Chi-square/df = 2.970, *p* = .000, GFI = .951, AGFI = .920, CFI = .980, RMSEA = .064, RMR = .032, NFI = .970

Figure 2. Revised model

Table 5. The Goodness-of-fit statistics for the hypothesized and revised model

Fit statistics	Hypothesized model	Revised model
$\chi^2$	166.314	166.314
df	62	56
<i>p</i> -value	.000	.000
$\chi^2/df$	4.397	2.970
GFI	.918	.951
AGFI	.880	.920
NFI	.951	.980
CFI	.962	.980
RMSEA	.083	.064

### 7.3 Path Coefficients and Explained Variance

The results of structural equation modeling analysis revealed the path coefficients, explained variance, standard error, critical ratio, and *p*-value as illustrated in Table 6.

Table 6. Path Coefficients and Explained Variance

Structural relationship	Std. Estimate	S.E.	C.R.	<i>p</i>
EE <--- SL	.49	.01	9.59	.001
QOSD <--- SL	-.13	.01	-3.14	.002
QOSD <--- EE	.90	.06	13.38	.001
AUT <--- SL	.86	-	-	-
STE <--- SL	.90	.02	25.82	.001
STA <--- SL	.92	.01	32.95	.001
HUM <--- SL	.81	.02	23.69	.001
EMP <--- SL	.85	.02	23.56	.001
IE <--- EE	.78	-	-	-
SE <--- EE	.78	.06	17.81	.001
AE <--- EE	.85	.06	19.48	.001
TAN <--- QOSD	.71	-	-	-
EMPA <--- QOSD	.83	.06	28.28	.001
ASS <--- QOSD	.90	.07	18.57	.001
RES <--- QOSD	.87	.07	18.13	.001
REL <--- QOSD	.89	.07	17.64	.001
R <sup>2</sup>				
EE	.235			
QOSD	.717			

The results revealed that servant leadership was positively related to employee engagement (.49). However, It was negatively related to the quality of service delivery (-.13). We also found a positive relationship between employee engagement and quality of service delivery (.90). The variance analysis indicated the servant leadership can explain 23.5% of the variance of employee engagement. In addition, the two predictors (servant leadership and employee engagement) can explain 71.7% of the variance in the quality of service delivery.

### 8. Conclusion

In recent years both servant leadership and employee engagement have enjoyed some attention in the organizational behavior literature. However, few studies have paid attention to the relationship between the two variables and the quality of service delivery. This study, therefore, tried to examine the relationship between these three variables in the Royal Thai Police. The results revealed interesting findings since there was a negative relationship between servant leadership and quality of service delivery. This finding is not consistent with some previous studies (Jaramillo et al., 2009; Hunter et al., 2013; Liu, Hu, & Cheng, 2015; Ling, Lin, & Wu, 2016). As the previous studies focused on private organizations which have quite a different context, characteristics of authority, and organizational culture, the present results, therefore, were not in line with the former one. However, an in-depth study on which type of leadership is more suitable for the police force should be conducted in the future. Anyway, servant leadership still being an important factor leading to employee engagement. When police officers have higher engagement, they are more likely to provide a good quality of service delivery to the public. Hence, promoting and enhancing employee engagement is a

very challenging task for the Royal Thai Police to gain trust and a good image and reputation.

## References:

- Almawali, H., Hafit, N. I. A., & Hassan, N. (2021). The mediating effects of employee engagement on motivational factors and job performance. *International Journal of Academic Research in Business and Social Sciences*, 11(12), 2316–2332.
- Anzalone, F.M. (2007). Servant leadership: A new model for law library leaders. *Law Library Journal*, 99(4), 793-812.
- Awan, K.Z., Qureshi, Ibn.E.W., & Arif, S. (2012). The effect of leadership style in NGOs: Impact of servant leadership style on employees' work performance and mediation effect of work motivation. *International Journal of Economics and Management Sciences*, 1(11), 43-56.
- Barbuto, J. E., & Wheeler, D. W. (2006). Scale development and construct clarification of servant leadership. *Group and Organization Management*, 31(3), 300–326.
- Bass, B. M. (2000). The future of leadership in learning organizations. *Journal of Leadership and Organizational Studies*, 7(3), 18–40.
- Carter, D., & Baghurst, T. (2014). The influence of servant leadership on restaurant employee engagement. *Journal of Business Ethics*, 124(3), 453-464.
- Chantaradecha, C., Supparerkchaisakul, N., Jongwisani, R., & Chaijukul, Y. (2014). The servant leadership in the private hospitals: A conceptualization and scale development. *Journal of Behavioral Science*, 20(2), 1-18.
- Chatbury, A., Beaty, D., & Kriek, H. S. (2011). Servant leadership, trust and implications for the “Base-of-the-Pyramid” segment in South Africa. *South African Journal of Business Management*, 42(4), 57-61.
- Chinomona, R., Mashiloane, M., & Poee, D. (2013). The influence of servant leadership on employee trust in a leader and commitment to the organization. *Mediterranean Journal of Social Sciences*, 4(14), 405-414.
- Cronin, J. J., & Taylor, S. A. (1992). Measuring service quality: a reexamination and extension. *Journal of Marketing*, 56(3), 55-68.
- Daft, R. (1999). *Leadership: Theory and practice*. Fort Worth, TX: Dryden Press.
- Dannhauser, Z., & Boshoff, A. B. (2006). The relationships between servant leadership, trust, team commitment and demographic variables. Retrieved 12 December 2019 from [http://www.regent.edu/acad/sls/publications/conference\\_proceedings/servant\\_leadership\\_roundtable/2006/pdf/dannhauser\\_boshoff.pdf](http://www.regent.edu/acad/sls/publications/conference_proceedings/servant_leadership_roundtable/2006/pdf/dannhauser_boshoff.pdf)
- Farah, A. (2023). Leadership in a youth movement as a transformative experience. *Journal of Innovations in Business and Industry*, 1(1), 23–31. <https://doi.org/10.61552/JIBI.2023.01.003>
- Faul, F., Erdfelder, E., Lang, A. G., & Buchner, A. (2007) G\*Power 3: A flexible statistical power analysis program for the social, behavioral, and biomedical sciences. *Behavior Research Methods*, 39, 175-191.
- Focht, A., & Ponton, M. (2015). Identifying primary characteristics of servant leadership: Delphi study. *International Journal of Leadership Studies*, 9(1), 44–60.
- George, S.S., Suppramaniam, S., & Arumugam, T. (2021). The impact of employee engagement and work culture on the productivity of employees in the IT industry in India. *Electronic Journal of Business and Management*, 6(4), 78-95.
- Gubman, L. E. (1998). *The talent solution: Aligning strategy and people to achieve extraordinary results*. The United States of America: McGraw-Hill.
- Hair, J. F., Black, W. C., Babin, B. J., & Anderson, R. E. (2010). *Multivariate data analysis* (7<sup>th</sup>ed.). New York: Pearson.
- Harwiki, W. (2016). The impact of servant leadership on organizational culture, organizational commitment, organizational citizenship behavior (OCB), and employee performance. *Procedia - Social and Behavioral Sciences*, 219(2016), 283 – 290.
- Hooper, D., Coughlan, J., & Mullen, M. (2008). Structural equation modelling: Guidelines for determining model fit. *Electronic Journal of Business Research Methods*, 6(1), 53-60.
- Hunter, E. M., Neubert, M. J., Perry, S. J., Witt, L. A., Penney, L. M., & Weinberger, E. (2013). Servant leaders inspire servant followers: Antecedents and outcomes for employees and the organization. *The Leadership Quarterly*, 24(2), 316–331.
- Jaiswal, N. K., & Dhar, R. L. (2017). The influence of servant leadership, trust in leader and thriving on employee creativity. *Leadership & Organization Development Journal*, 38(1), 2-21.
- Jaramillo, F., Grisaffe, D. B., Chonko, L. B., & Roberts, J. A. (2009). Examining the impact of servant leadership on salesperson's turnover intention. *Journal of Personal Selling & Sales*, 29(4), 351-365.



- Kahn, W. A. (1990). Psychological conditions of personal engagement and disengagement at work. *Academy of Management Journal*, 33(4), 692–724.
- Keith, K. M. (2008). *The case for servant leadership*. Westfield, IN: Greenleaf Center for Servant Leadership.
- Khatibi, A., Asadi, H., & Hamidi, M. (2009). The relationship between job stress and organizational commitment in National Olympic and Paralympic Academy. *World Journal of Sport Sciences*, 2(4), 272–278.
- Laub, J. A. (1999). Assessing the servant organization: development of the organizational leadership assessment (OLA) instrument. *Dissertation Abstracts Online*, 60(2), 308A.
- Liden, R. C., Wayne, S. J., Zhao, H., & Henderson, D. (2008). Servant leadership: development of a multidimensional measure and multilevel assessment. *The Leadership Quarterly*, 19(2), 161–177.
- Ling, Q., Lin, M., & Wu, X. (2016). The trickle-down effect of servant leadership on frontline employee service behaviors and performance: A multilevel study of Chinese hotels. *Tourism Management*, 52(2016), 341–368.
- Liu, B., Hu, W., & Cheng, Y.C. (2015). From the west to the east: Validating servant leadership in the Chinese public sector. *Public Personnel Management*, 44(1), 25–45.
- Meemoei, T., Jongwisar, R., & Sakdiworapong, C. (2011). Servant leadership, spirituality in organization and job performance of managers in a private food industry business in Bangkok. *The Journal of KMUTNB*, 21(2), 447–455.
- Minh Tri, N. (2023). Social justice in Vietnam: Reality and solutions. *Journal of Innovations in Business and Industry*, 1(2), 93–102. <https://doi.org/10.61552/JIBI.2023.02.006>
- Mittal, R., & Dorfman, P. W. (2012). Servant leadership across cultures. *Journal of World Business*, 47(4), 555–570.
- Muller, R., Smith, E., & Lillah, R. (2018). The impact of employee engagement on organizational performance: A balanced scorecard approach. *International Journal of Economics and Finance studies*, 10(2), 22–38.
- Musyoka, S. T., Ochieng, I., & Ozioki, P. M. (2016). Factors affecting provision of quality service in the public health sector: A case of Nyahururu District Hospital, Kenya. *International Journal of Management and Economics Invention*, 2(9), 852–896.
- Ngumbao, E., & Muturi, P. M. (2018). Influence of employee engagement strategies on service delivery in Nairobi City County, Kenya. *Journal of International Business and Management*, 1(3), 1–10.
- Page, D., & Wong, T. P. (2002). *Conceptual framework for measuring servant leadership. In the human factor in shaping the course of history & development*. Lanham: University Press of America.
- Parasuraman, A., Zeithaml, V., & Berry, L.L. (1988). SERVQUAL: A multiple - item scale for measuring consumer perceptions of service quality. *Journal of Retailing*, 62(1), 12–40.
- Parris, D. L., & Peachey, J. W. (2013). A systematic literature review of servant leadership theory in organizational contexts. *Journal of Business Ethics*, 113(3), 377–393.
- Pipitvej, N. (2014). Leadership and work engagement of generation Y employees in Thailand. Proceedings of the 10th Asian Business Research Conference, 6 - 7 October 2014, Bangkok, Thailand.
- Rasheed, A., & Lodhi, R. N. (2015). Relationship between servant leadership and employee innovate work behavior: Role of work engagement as mediator. *Science International (Lahore)*, 27(5), 4681–4686.
- Rayan, A., Wong, J. P., & Bañas, J. L. P. (2015). Influence of servant leadership among government employees in the province of Romblon, Philippines. *International Journal of Humanities Social Sciences and Education (IJHSSE)*, 2(12), 73–81.
- Reed, L. L., Vidaver-Cohen, D., & Colwell, S. R. (2011). A new scale to measure executive servant leadership: development, analysis, and implications for research. *Journal of Business Ethics*, 101(3), 415–434.
- Reinke, S. J. (2004). Service before self: towards a theory of servant leadership. *Global Virtue Ethics Review*, 5(3), 30–57.
- Rich, B. L., Lepine, J. A., & Crawford, E. R. (2010). Job engagement: Antecedents and effects on job performance. *Academy of Management Journal*, 53(3), 617–635.
- Robbins, S. P., & Judge, T. A. (2017). *Organizational behavior (17<sup>th</sup>ed.)*. Essex: Pearson Education Limited.
- Robinson, D., Hooker, H., & Hayday, S. (2007) *Engagement: The continuing story*. Brighton, UK: Institute for Employment Studies.
- Russell, R. F., & Stone, A. G. (2002). A review of servant leadership attributes: developing a practical model. *Leadership and Organization Development Journal*, 23(3), 145–157.
- Rust, R. T., & Oliver, R. L. (1994). Service quality: insights and managerial implications from the frontier in R. T. Rust and R. L. Oliver (eds.) *Service Quality: New Directions in Theory and Practice*, pp. 1–19. California: Sage.
- Salge, T. O., & Vera, A. (2012). Benefiting from public sector innovation: The moderating role of customer and learning orientation. *Public Administration Review*, 72(4), 550–560.

- Sarangi, P., & Nayak, B. (2018). Employee Engagement and Its Impact on Organizational Success– A Study in Manufacturing Company, India. *IOSR Journal of Business and Management*, 18(4), 52-57.
- Schaufeli, W. B., & Bakker, A. B. (2003). UWES: Utrecht Work Engagement Scale. Preliminary Manual, Department of Psychology, Utrecht University, The Netherlands.
- Shirom, A. (2004). Feeling vigorous at work? The construct of vigor and the study of positive affect in organizations. In D. Ganster and P.L. Perrewe (eds.) *Research in Organizational Stress and Well-being*, Vol. 3, Greenwich, CT: JAI Press, 135-165.
- Shrestha, R. (2019). Employee engagement and organizational performance of public enterprises in Nepal. *International Research Journal of Management Science*, 4(1), 118-135.
- Soane, E., Truss, K., Alfes, K., Shantz, A., Rees, C., & Gatenby, M. (2012) Development and application of a new measure of employee engagement: the ISA Engagement Scale. *Human Resource Development International*, 15(5), 529-547.
- Sousa, C. M. P., & Van Dierendonck, D. (2015). Servant leadership and the effect of the interaction between humility, action, and hierarchical power on follower engagement. *Journal of Business Ethics*, 141(1), 13-25.
- Spears, L. C. (2004). Practicing servant-leadership. *Leader to Leader*, 34, 7-11.
- Suksawang, P. (2013). *Structural equation modeling*. Bangkok: Thai Wattana Panich.
- Sungmala, N. (2021). The effect of employee engagement on organizational performance in multinational company (MNCs) in Thailand (Unpublished Doctoral Dissertation, Graduate School, Silpakorn University).
- Tabachnick, B. G., & Fidell, L. S. (2007). *Using multivariate statistics* (5<sup>th</sup>ed.). New York: Allyn and Bacon.
- van Dierendonck, D. (2011). Servant leadership: a review and synthesis. *Journal of Management*, 37(4), 1228–1261.
- Wanjau, K. N., Muiruri, B. W., & Ayodo, E. (2012). Factors affecting provision of service quality in the public health sector: A case of Kenyatta National Hospital. *International Journal of Humanities and Social Science*, 2(13), 114-125.
- Wheaton, B., Muthen, B., Alwin, D., F., & Summers, G. (1977). Assessing reliability and stability in panel models. *Sociological Methodology*, 8(1), 84-136.
- Wong, C. A., & Laschinger, H. K. (2015). The influence of frontline manager job strain on burnout, commitment and turnover intention: a cross-sectional study. *International Journal of Nursing Studies*, 52(12), 1824-1833.
- Wushe, T., & Shenje, J. (2019). The antecedents of employee engagement and their effect on public sector service delivery: The case study of government departments in Harare. *SA Journal of Human Resource Management*, 17(0), a1082.
- Yoshida, D. T., Sendjaya, S., Hirst, G., & Cooper, B. (2014). Does servant leadership foster creativity and innovation? A multi-level mediation study of identification and prototypicality. *Journal of Business Research*, 67(7), 1395–1404.
- Zumrah, A. R. (2014). Service quality in Malaysian public sector: The role of transfer of training. *Procedia - Social and Behavioral Sciences*, 144, 111 – 117.

---

**Waiphot Kulachai**

SuanSunandha Rajabhat University, Bangkok,  
Thailand  
[waiphot.ku@ssru.ac.th](mailto:waiphot.ku@ssru.ac.th)  
ORCID 0000-0002-3476-9462

**Layla Kurniawati**

InstitutPemerintahanDalamNegeri,  
Sumedang, Indonesia  
[lavlakurniawati@ipdn.ac.id](mailto:lavlakurniawati@ipdn.ac.id)  
ORCID 0000-0001-5045-376X

**Patipol Homyamyen**

Rajamangala University of Technology  
Suvarnabhumi,  
Suphanburi,  
Thailand  
[patipol.h@rmutsb.ac.th](mailto:patipol.h@rmutsb.ac.th)  
ORCID 0000-0002-7261-2693

**Pennapa Pornsupikul**

Road Safety Policy Foundation  
Bangkok, Thailand  
[pennapa@roadsafetythai.org](mailto:pennapa@roadsafetythai.org)  
ORCID 0000-0003-4775-1007

**Thaywuse Borriraksuntikul**

Ministry of Interior  
Bangkok, Thailand  
[thaywut@hotmail.com](mailto:thaywut@hotmail.com)  
ORCID 0000-0001-5864-8430

---