



THE ROLE OF TRAJECTORY IN THE FUNCTION OF RESEARCH PTO TRANSMISSIONS

Dragisa Micic¹
Zorica Lazic

Received 01.04.2022.
Accepted 30.06.2022.
UDC – 621.83

Keywords:

Cardan gears; Turning circle; Four-member gears; Radius of curvature; Trajectory

ABSTRACT

In this paper, the kinematics of the motion of an inner moving circle along a twice as large fixed outer circle will be considered. Such circles are known in science as Cardan circles. Specifically, within this topic of the paper, cases will be presented where when rolling a small cardan circle within a large cardan circle, all points along the circumference of the small cardan circle will describe straight lines, which correspond to the diameter of the large cardan circle in length and position. Particular attention is paid to the determination of the turning circle as well as all other kinematic parameters in four-member transmissions.



© 2022 Published by Faculty of Engineering

1. INTRODUCTION

As is well known, every plane motion can be represented as rolling a moving centroid on a stationary one without sliding. It is believed that one of the greatest contributions in the field of this research was made by the Milan physician, engineer and mathematician Gerolamo Cardano (1501 - 1576). For us, the most important is Cardan's observation, which refers to the kinematics of the motion of an inner moving circle along a twice as large fixed outer circle. In science, such circles are known as Cardan circles (Figure 1).

When the inner Cardan circle 2 rolls without sliding along the outer side of the circle 1, then we have that each point on the circumference of the smaller circle defines a straight line in a plane related to circle 1. These lines pass through the center O of a fixed circle, and their lengths are the same as its diameter. Point B (Figure 1) would move along the vertical axis and point A along the

horizontal axis. All other points of the plane of the less moving circle 2 would describe elliptical trajectories on the fixed plane of the circle 1. Based on this theory, at the end of the 18th century, three-membered toothed planetary mechanisms were made with point guidance along a straight trajectory.

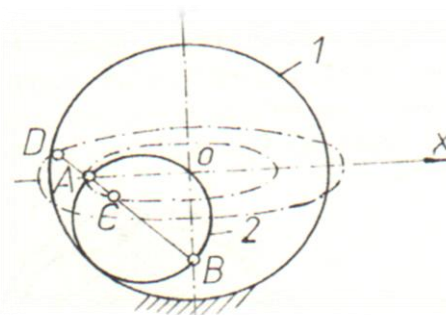

Figure 1. Cardan circle

¹ Corresponding author: Dragisa Micic
Email: micicdr59@gmail.com

By selecting any point of the moving plane of the Cardan system and studying the path of its current center, the result is that the non-moving centroid is a circle, as well as the moving centroid, only with a diameter twice smaller than the non-moving one. Both centroids are located on the same side of the tangent of the current center. As all those plane motions, where the centroids are circles, are called cycloid motions, Cardan motion is a special case of this group of motions. Therefore, Cardan motion is defined as the motion obtained when one circle rolls without sliding on the inner side of a circle of twice the diameter.

2. THE CARDAN ISSUE

Figure 2 displays a pair of Cardan circles with a diameter ratio of 1: 2. When rolling a small Cardan circle inside a large one, all the points of circumference of the small Cardan circle will describe straight lines, which correspond to the diameter of the large cardan circle in length and position. This is a particular case of the shape of curved couplers, whose curves are equal to zero. Figure 3 illustrates all possible movements in the Cardan system more closely. On the small cardan circle, in addition to the circumferential points B and K, describing the rectilinear paths, there are also points A, C, D and E. Point A is the center of the circle, which is known to describe the circular path. Points C, D, E lie in the plane of a small cardan circle and describe elliptical trajectories, whose large and small semi-axes can be very easily determined. First, the distance of such a point from the center of the small cardan circle is increased by the radius of the small cardan circle. Then, the same distance is reduced by the radius of the small cardan circle. It is now easily perceptible that the rectilinear trajectories of points B and K and the circular trajectories of point A are nothing but exceptional boundary shapes of the ellipse, once with a small semi-axis equal to zero and another time with the axes of an ellipse of equivalent magnitude. In the gears mentioned so far, circumferential points of circles such as B and K have always been used, together with the center of circle A or with the circumferences of the circle itself, but the second elliptical walking point has never taken part in the process of motion design. However, an elliptical trajectory or at least such suitable elements as the vertex curvature circles can also be applied. (Figure 4). Figure 3 displays a small cardan circle forcibly guided by an OA curve and by rolling inside a large cardan circle. An additional built-in rotating lever O_1D (Figure 3) limits the range of motion to the part of the large upright ellipse, where the vertexes of the curves approach the circle nicely. More precisely, it is the domain in which the smallest deviation between the variable radius of curvature of the ellipse and the constant length of rotating lever O_1D does not exceed the total tolerance, which results from the total joint clearance in the gear unit.

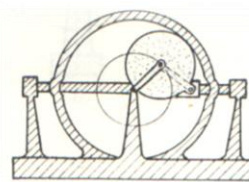

Figure 2. Particular case of the shape of curved couplers

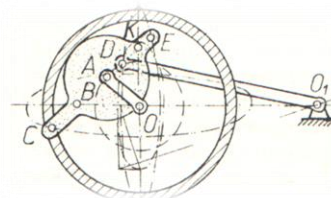

Figure 3. Possible movements of the cardan system

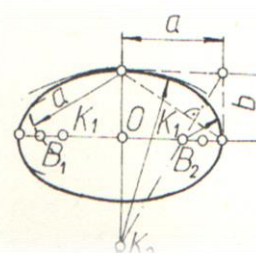

Figure 4. Elliptical path construction

Based on this example, a wide range of possibilities of approximately rectilinear point guidance arises, ie. obtaining approximate cardan movement (Figure 5). In all gears (Figure 5) the rectilinear guidance of point B (by the circumference of the small cardan circle) is retained, while the OA curve of the gear (Figure 5a) is replaced by rotary levers in other gears (Figure 5b, Figure 5c, Figure 5d), which describe the vertex circles, whose curve coincides with the ellipse, given in Figure 3. In the case of a gear (Figure 5b), point C describes an ellipse, while in Figure 5c the ellipse is described by point D. Figure 5d displays the ellipse described by the point E. In all the above gears (Figure 5), point K (on the circumference of a small cardan circle) is guided along a line p , while the newly introduced rotating levers describe elliptical trajectories.

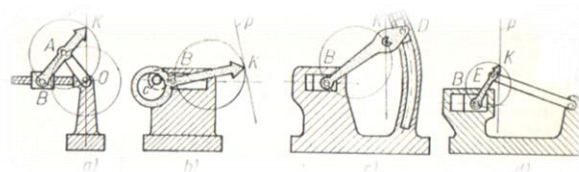

Figure 5. Gears with approximate cardan movement

This is not the case only for an arbitrarily chosen point K, but for all points on the circumference of a small cardan circle. All these points describe shorter or longer, but correct rectilinear paths, which are directed towards the center of the large cardan circle, ie. according to the

intersection point of the directions of rectilinear guidance of points B and K.

The gears discussed below were very popular at the beginning of their discovery and found the use for rectilinear guidance both for writings on indicators and for guiding machines and pumps. However, their significance is particular nowadays for the practical application of the curves, which describe the guiding point of the coupler of a mechanism. But if the path of the point K is not a suitable one, then any other point can be chosen on the small cardan circle, representing a better shape of the curve.

2.1 Cardan motion and coupler movement

The scientist Rau replaced the rectilinear motion of point B (Figure 5) with a circle of curvature of the elliptical path and a corresponding rotating lever, obtaining an articulated quadrilateral where all points of coupler lying on the circumference of the imaginary cardan of this circle, have rectilinear parts of the path. In Figure 6, for example, point E, as a point of the plane of the small cardan circle, describes an ellipse, which has a radius of curvature in the shown position of the small cardan circle. In Figure 7, this radius of curvature is presented as a *walker*. The axis of the *walker* E thus moves along a circle around the fixed bearing of the walker, which as a circle of elliptical curve approximates the ellipse on that part of the path with great accuracy, as shown in the figure by a solid line. The same ellipse would be described by point E, as a point of a small cardan circle. As one of the points in the plane of the small cardan circle, its center A describes a circle around the center C (switching pole) of the large cardan circle, which is used as a curve circle with the aid of the CA curve (Figure 7). The path of the axis of curve A completely overlaps here with the path of point A, as the center of a small cardan circle. Points E and A are at the same time points of one rigid plane, which is a plane of a small cardan circle in Figure 6, whereas in Figure 7 it is a plane of a coupler. With reference to the subject mentioned above, the result is that the plane of the coupler in Figure 7 moves for a very long time in the same way as the plane of the small cardan circle in Figure 6., while the motion of point E on the cardan ellipse can be replaced by the motion of the same point E along the line of curvature of the cardan ellipse. This again means that the laws of motion of the coupler plane can be replaced by much simpler equations of the ellipse of cardan motion in this domain, which as second-degree equations lie in the field of elementary mathematics. However, in each position of the gear there are coupler points, whose path curves at one point have zero value. The curves in such places look approximately like straight lines. Therefore, the paths of the coupler points have inflectional/bending points. The radius of curvature is then infinitely large, so that at these points the normal acceleration has zero value. As all points of circumference of a small cardan circle have rectilinear paths, as a result, they do not have normal acceleration.

Recognizing this fact is of fundamental importance for the further development of Rau's theory of approximate cardan motion.

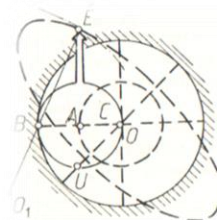

Figure 6. Path point E a small cardan circle

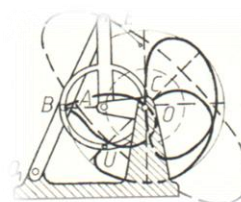

Figure 7. Path point of gear

2.2 Approach to the turning circle determination

When referring to each square gear, there are coupler points in each position, whose normal acceleration at one point has a value of zero. They then pass a point on their path called a flat point. It can be proved that such a coupler point, without taking into account the special positions, lies on a circle in the plane of the coupler. Such a circle is called a **turning circle** or a normal circle. Besides, there are coupler points in each position, whose tangential acceleration at one point has value zero, which means that they occasionally move in an equal manner. Such coupler points are located in the plane of the coupler, again not taking into account the special positions, also on the circle, which is called the **tangential circle**. The turning circle and the tangential circle, the so-called Bresse's circles, intersect at two points, at the velocity pole P and at the acceleration pole J (Figure 8). The center of the turning circle lies on the normal of the pole trajectory, the center of the tangential circle lies on the tangent of the pole trajectory. The normal of the pole trajectory and the tangent of the pole trajectory, the determination of which is still being explained and on the basis of Figure 10, all the way to the Figure 13, should be considered as an axial cross in the plane of the coupler and facilitates the determination of individual coupler points. While the velocities of the arbitrary coupler points are related to each other as their distances from half the velocity, thus the accelerations of the arbitrary coupler points in relation to their distances from half the acceleration are obtained. The precondition is that, for some coupler point, the speed and acceleration according to the size and direction are known. If the velocities in this direction of action are plotted as vectors, then they always stand at right angles to the corresponding pole beam P. Figure 8 shows the curve of

the walker in the internal dead position. The center line of the coupler closes with a *tangent of the pole path*, angle φ . In addition to the two coupler joints A and B, four more coupler points were tested on the centerline of the coupler : K₁, K₂, K₃, and K₄.

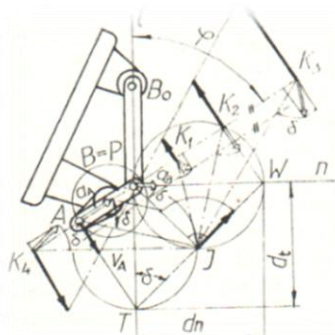

Figure 8. Bresse's circles

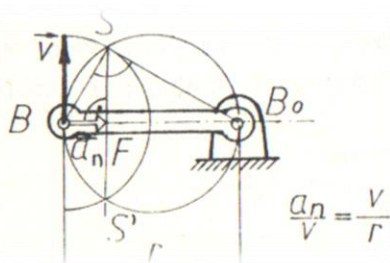

Figure 9. Normal acceleration construction

Their velocities stand at right angles to the coupler midline, the lengths of the vectors are derived when air is drawn through the vertex of the vector v_A and the pole P. As opposed to velocities, the acceleration vectors close the same angle δ to each other with the beam poles to the acceleration pole J, for each gear position, which is normally less than 90° .

90° . The acceleration vectors of the various coupler points in Figure 8 are determined by plotting a parallel line to the present coupler line. This line passes through a single point on the pole ray AJ, which is obtained when the acceleration vector a_A from its position on the curve midline (normal acceleration) coincides by the angle on the pole sign AJ. At certain signs of the pole, for the respective coupler points, the obtained lengths of the vector must then overlap by an angle in the respective sense, when they want to show their direction of action.

The vector vertex lies in the curve bearing A_0 , so in that case the length of the vector is equal to the length of the curve. This follows from the construction of normal acceleration (Figure 9), when the speed of the curve axis v_A is chosen, equal to the length of the curve.

The acceleration vector for the walker axis, here at the same time the pole of velocity P, lies on the normal path of the pole. This acceleration cannot be considered either as a tangential acceleration, or a normal acceleration, but this is an inflectional acceleration, since the walker axis B lies here in its dead position. The angle between the acceleration vector a_B and the corresponding pole beam to J appears in the turning circle, as a circumferential angle above the tendon JW. It follows that for all couplerpoints on a bending circle, for example for a coupler point K₂, the angle between the acceleration vector and its pole beam must appear as a circumferential angle above the same tendon. The direction of the acceleration vector for arbitrary points on the turning circle therefore coincides with the direction of the velocity vector. Thus, acceleration can only be tangential. All coupler points on the turning circle pass through the turning points. For the coupler points on the turning circle, an acceleration vector arises, the normal component of which is directed from the pole. The coupler curve of such a coupler point K₁ must appear convex, viewed from the pole, since, as is well known, the direction of normal acceleration is always directed radially towards the curvature centre. For coupler points outside the turning circle, for example K₃ or K₄, a normal component arises, which is directed towards the pole, which means that the respective places of the couplercurves, viewed from the pole point, must look concave. The intersection point of the turning circle with the normal of the pole path is the turning pole W, and the intersection point of the tangential circle with the tangent of the pole path is the tangential pole T. The triangle PTW closes the tangent angle δ at the pole. This angle is the circumferential angle above the tendon PJ in the tangential circle. The same circumferential angle applies to all other points on the tangential circle, in relation to the same tendon PJ. Therefore, as can be seen from the example of the curve axis A, that the velocity and acceleration vectors for all points on the circumference of the tangential circle stand at right angles to each other. The resulting accelerations can only be normal accelerations. The acceleration pole J, as the coupler point and the intersection point of both circles, passes one inflectional/bending/ turning point of its path, while the velocity pole P, as the coupler point and also as the intersection point of both circles, is standing still and gets the inflectional acceleration.

For the ratio of two diameters of the tangential circle d_t and the turning circle d_w , it holds

$$\frac{d_t}{d_w} = ctg\delta \quad (1)$$

Thus, the diameter of a tangential circle can be determined, when the diameter of the turning circle and the angle φ are known. The following formula is also used for the diameter of a tangential circle.

$$d_t = \frac{AP}{\cos\varphi} \quad (2)$$

Along with the distance between the pole P and the axis of the curve A, which can be taken from the drawing, the angle of the pole beam φ , measured according to the tangent of the pole trajectory, is required to determine the diameter of a tangential circle. It follows that the position of the tangent of the pole path must first be determined. The position of the tangent pole P and the magnitude of the beam angle of the pole φ , must be determined by the auxiliary structure, which is given in Figure 10 a and Figure 10 b, presented for the walker. The current pole P is located as the intersection point of the midlines (straight lines through the joint points) of the curve and the walker. This gives values for distances PK and PM. The axis of the walker is marked here with K (coupler point), and the bearings of the walker with M (curvature center). The center lines (straight lines through the joint points) of the base and the coupler intersect at the relative pole Q. The straight line through the relative pole Q and the instantaneous pole P is the so-called *collinear axis* or *collineation axis* and closes the angle with the pole curve beam, which, but in the opposite direction, must be applied to the pole walker beam, in order to obtain the tangent of the pole trajectory as its free angle arm. To find the angle of the pole beam (φ), the angle for the walker is between the tangent of the pole trajectory and pole walker beam, or between the collinear axis and the pole curve beam. To calculate the diameter of the turning circle, the application of the tangent of the pole trajectory into the auxiliary structure can be omitted. This method of calculating the diameter of the turning circle has a disadvantage – it lies in the need for auxiliary construction and in measuring the required distances PK and PM and the angle of pole beam (φ) in it, because it must be very accurately drawn and very carefully measured, especially the angle of pole beam (φ), if some major inaccuracies are to be avoided. The construction of the turning circle diameter is possible without using the angle of pole beam (φ). It is only necessary to construct the tendon of the turning circle, for each pole of each base of the bearing member (curve, walker) of the respective gear. As Figure 11 shows, the verticals intersect at the endpoints of these tendons at the turning pole W. The distance between the current pole P and the turning pole W is the diameter of the turning circle d_w (and at the same time the normal of the pole trajectory). Sometimes the assessment of diameter of the turning circle, when the tangent of the pole trajectory is being detected according to Figure 10 a or Figure 10 b, but also the vertical in the current pole W is immediately drawn, the normal of the pole trajectory (Figure 12). Then only one of the tendons of the turning circle must be drawn, whose vertical at the end point of the tendon S intersects the normal of the pole trajectory at the inflectional/bending point W. Between the pole P and the turning point W lies the diameter of the turning circle.

The determination of the tendon of the turning circle is shown in Figure 13 for the pole curve beam, and in Figure 12 for the pole walker beam. The current pole P is obtained, as is already known, as the intersection of the curve centerline/midline and the walker midline (straight line through the joint points). The straight line 1 should be drawn through the axis of the curve K (Figure 13), at right angles, towards the centerline of the curve, plus the parallel 2, through the current pole P. On the straight line 1 through the axis of the curve K, the distance PK is applied, with the endpoint T, through which then the straight line 4 is drawn from the bearing of the curve M, which intersects the parallel through the current pole 2 at the point. The distance has the length of the required tendon of the turning circle PS in the pole curve beam 5. On the vertical 6 at the end point of the tendon S, lies the turning pole W (Figure 11). The corresponding construction in Figure 12 follows in the same way. The points K and M are then only the axis and the bearing of the walker 1. Since the angle between the pole curve beam and the line 1 is arbitrary, through the axis of the curve K, then it is selected the way the line 1 coincides with the centerline of the coupler, as it is done in Figure 13 b for the construction of Figure 13 a. The advantages of this position of line 1 lie in the fact that this line then passes through the axis of the walker and therefore, as well as the parallel line 2, through the current pole P, it can be used both for determining the tendon of the turning circle along the pole curve beam and for determining the tendon of the turning circle in the air of the pole walker beam, which is shown in Figure 14. The construction is not only considerably simplified, but above all, it is made more accurate due to the elimination of some sources of error. The dependence between the turning circle and the walker curvature is shown in Figure 15. Figure 15 shows the position of the walker in the internal dead position. The axis of the walker B coincides with the pole P, and the bearing of the curve A_0 with the relative pole Q. The midline of the coupler is at the same time the collinear axis (collineation axis), and it coincides with the pole curve beam as well.

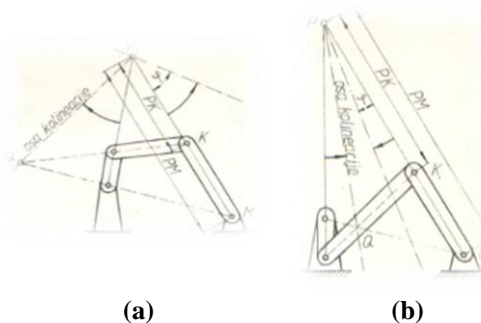

Figure 10. Determining the position of the tangent of the pole path

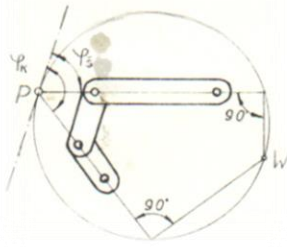

Figure 11. Construction of the diameter

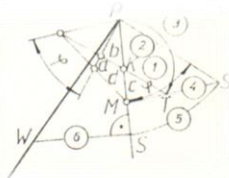

Figure 12. The determination of the tendon of the turning circle is shown for the pole walker beam

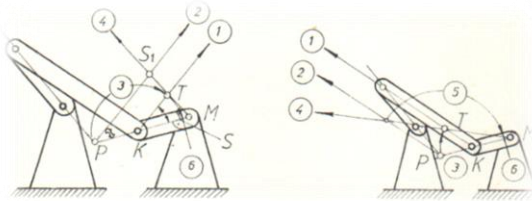

Figure 13. The determination of the tendon of the turning circle is shown for the pole curve beam

Figure 8 and Figure 15 both show the position of the gear in the plane of the image, so that the tangent of the pole trajectory t stands vertically and the normal of the pole trajectory horizontally, while the turning circle lies to the right of the tangent of the pole trajectory. This makes it easier to compare two images. The position of the turning circle and its side of the tangent of the pole trajectory depends on the direction of the curve of the coupler point, which serves as the basis for determining the turning circle. In this case, it is the axis of the curve A. When the circle of the curve in the area of the axis of the curve from the direction of the pole looks convex, then the axis of the curve lies in the turning circle, and if it looks concave, then the axis of the curve lies outside the circle of rotation (Figure 8 and Figure 15).

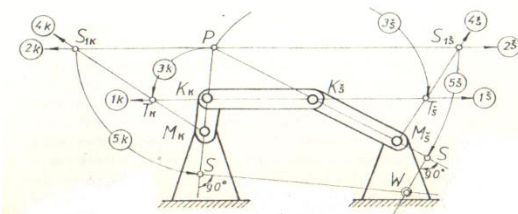

Figure 14. The determination of the tendon of the turning circle is shown for the pole curve beam and for the pole walker beam

It follows from the above that the tangent of the pole trajectory coincides with the pole walker beam, since the angle to be applied has a value of zero, according to Figure 10 a. Thus, a particularly clear picture is obtained. Due to the rotation of the curve, the pole P moves in the direction of the tangent of the pole trajectory with alternating speed of the pole V. This can be decomposed into two mutually perpendicular components in the direction of the pole beam and transversely to the pole beam, in relation to the pole curve beam. The component in a transverse position to the pole beam is particularly important here with size $v \sin \varphi$.

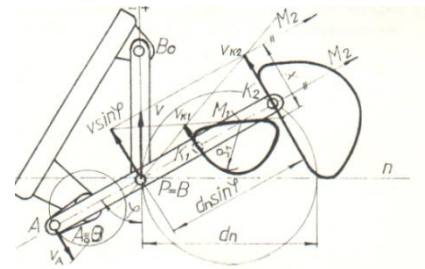

Figure 15. Position of the walker in the internal dead position

Afterwards, the following proportions can be set

$$\frac{v \sin \varphi}{v_A} = \frac{\overline{PA_0}}{\overline{PA} - \overline{PA_0}} = \frac{\overline{PA_0}}{a} \quad (3)$$

$$\frac{n \sin \varphi}{v_K} = \frac{\overline{PM}}{\overline{PM} - \overline{PK}} = \frac{\overline{PM}}{\rho} \quad (4)$$

For the point K_1 , the corresponding center of the curve M_1 is found as the point of intersection of the pole beam through K_1 with the connecting line of the vertices of the vector of $v \sin \varphi$ and for the coupler point K_2 whose trajectory currently has a curve of zero value, the corresponding center of the curve M_2 must lie at infinity. This is the case when the connecting line of the vertex of the vector passes parallel to the pole beam, in other words, when $v \sin \varphi = v_{K_2}$. By definition, this point must then lie on the turning circle, since all points on the turning circle do not have normal acceleration. The distance of pole of the coupler point K_2 is the tendon of the turning circle of length $d_w \sin \varphi$.

The resulting proportions are:

$$\frac{d_w \sin \varphi}{-PA} = \frac{v_K}{v_A} = \frac{v \sin \varphi}{v_A} = \frac{\overline{PA_0}}{-\overline{PA} + \overline{PA_0}} \quad (5)$$

Therefore, we get the diameter of the turning circle:

$$d_w = \frac{\overline{PA} \overline{PA_0}}{(\overline{PA} - \overline{PA_0}) \sin \varphi} \text{ [cm]} \quad (6)$$

According to the Formula 2, since the diameter of a tangential circle is also known, then the acceleration pole J also arises as the intersection point of both circles.

2.3 Euler-Savary approach for determining the curvature of coupler curves

For an arbitrary gear position, for the known diameter of the turning circle d_w , the calculation of the corresponding center of the curvature M for each point of the coupler K can be easily made. Using the example of the K_1 coupler point, Figure 15 shows the following:

$$\frac{\overline{PM_1}}{d_w \sin \varphi} = \frac{v \sin \varphi}{x} = \frac{\overline{PK_1}}{d_w \sin \varphi - \overline{PK_1}} \quad (7)$$

Based on this, the distance of the pole of the curvature center generally follows:

$$\overline{PM} = \frac{\overline{PK}}{d_w \sin \varphi - \overline{PK}} \frac{d_w \sin \varphi}{\overline{PK}} \text{ [cm]} \quad (8)$$

To use this formula, the first thing to calculate is the diameter of the turning circle d_w according to formula (6). Formula (8) can then be applied to any arbitrary pole beam and again to any arbitrary coupler point. The angle not exceeding 90° can always be used as the pole beam angle, paying attention to the sign rule for the pole distance. All distances on the side of the tangent of the pole trajectory on which the turning circle lies have a positive sign, and all distances on the other side have a negative sign.

The position of the turning circle

The position of the turning circle to the tangent of the pole path is determined according to the fact that the paths of joints A and B are also circles, circular arcs or straight lines. If there are circular curvatures, then the coupler joints lie inside the turning circle, if their path towards the pole P is convex. However, if the circular curvature rotates its concave side to the pole P, then such coupler joints lie outside the turning circle. A straight-water joint lies on the turning circle. Formula (8) is known as **the Euler-Savary formula**. If the corresponding coupler point for a given center of the curve is to be determined, by arranging the formula you get that

$$\overline{PK} = \frac{\overline{PM}}{d_w \sin \varphi + \overline{PM}} \frac{d_w \sin \varphi}{\overline{PM}} \text{ [cm]} \quad (9)$$

The following formula for the radius of curvature of the coupler curve applies in any case.

$$\rho = |\overline{PM} - \overline{PK}| \text{ [cm]} \quad (10)$$

With each articulated four-member gear, the position of the turning circle changes depending on the position and size of the gear members. If the area of coupler curves with a relatively constant curvature is required in a gearbox design, it is appropriate to give preference to those areas in which the diameter of the turning circle d_w has an extreme value. The relative change in the diameter of the turning circle d_w is always the smallest in the area of its extreme values. It follows that the influence of the diameter of the turning circle d_w on the curvature relations in the plane of the coupler derives from the Euler – Savary formula. Therefore, some relatively minimal changes can be expected, when preference is given to such areas of the transmissions, in which the diameter of the turning circle d_w is slightly changed.

3. FUNDAMENTALS OF KINEMATIC GEOMETRY OF INFINITELY CLOSE POSITIONS OF CURRENT CARDAN MOTION

A concept that has proven to be very useful in the design of mechanisms is the Cardan plane motion (Levitskii, 1981; Rusov, 1980; Kornejcuk, 1976; Dijksman, 1980; Bloh, 1981; Norton, 2001; Uicker et al., 2003). It can be interpreted in the case of water movement, as the special position of the moving plane in which the movement of all points on it is similar to the one realized in the Cardan motion. In the new literature and papers dealing with this area, when referring, the term "geometry of current kinematics" is increasingly used. This expression refers to both the plane and the spatial problem. The founder of this field of kinematics is considered to be Miller/Müller Reinhold. At the end of the last century, with a series of works, he laid the foundations of the theory of kinematics of infinitely close positions. Sometimes, in the design of mechanisms, it is preferable for a member AB to have such a motion, so that the paths of its points A and B are tangents at some point with the desired paths, rather than simply intersecting those paths at several different points. For the paths of points A and B to be tangents to the desired paths, this could be achieved by requiring that positions 1 and 2 be infinitely close to each other at the moment of motion, when we want the tangential direction of the paths to be achieved. This position can be marked with A_{12} and B_{12} . The pole P_{12} is transformed into the current velocity center, i.e. rotations for member AB. (Figure 16).

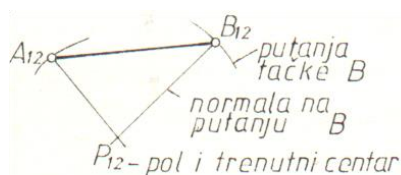

Figure 16. Current velocity center*

*Putanja tačke B - Point B path.,
Normala na putanju B - Normal on the path B,
Pol i trenutni centar - pole and current center

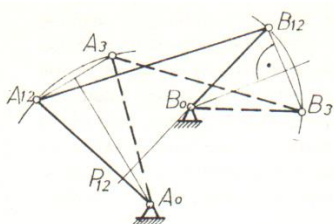

Figure 17. Two infinitely close positions

If we want the moving plane AB to achieve movement with the mentioned characteristics, it could be performed using a four-member articulated mechanism that meets the following requirements: the center point (fixed bearing) corresponding to the point A_{12} of the circle must be at any point of the normal on the path, more precisely, on the line $P_{12}A_{12}$, and the corresponding center of the point B_{12} on the line $B_{12}P_{12}$. If we want the moving plane AB to have such a motion that the trajectories of points A and B are tangents to the desired trajectories in one position and pass through the another non-tangential position, we can identify the first position as 1 - 2 (infinitely close) and the non-tangential position as position 3 (Figure 17). Then, such a movement can also be performed using an articulated quadrilateral. If point A is desired to be a movable bearing, then the corresponding fixed bearing A_0 will be located at the intersection of the line $A_{12}P_{12}$ and normal bisector on

$A_{12}A_3$. The fixed bearing B_0 is located in the same way.

If the moving plane AB should perform such a movement, so that the trajectories of its points A and B in a certain position are even closer to the desired trajectories, then we can ask for three positions of the plane, infinitely close to each other. In this case, since the curvature circle for a curve at a given point is defined as a circle having "third-order contact" with the curve (coinciding with the curve at three infinitely close points), the fixed bearings A_0 and B_0 of the articulated quadrilateral that would perform such a motion would be located at the curvature centers of the curves at points A_{123} and B_{123} .

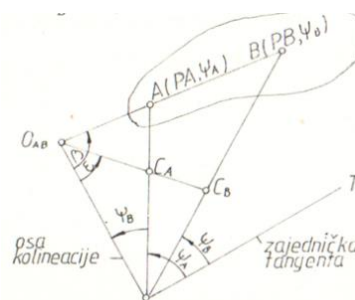

Figure 18. Distances according to Euler-Savary equations

$$\left(\frac{1}{PA} - \frac{1}{PC_A}\right) \sin \psi_A = \left(\frac{1}{PB} - \frac{1}{PC_B}\right) \sin \psi_B = \left(\frac{1}{PC} - \frac{1}{PC_C}\right) \sin \psi_C \quad (11)$$

P - current rotation center, located in cross section AC_A, BC_B, CC_C ,

ψ_A - the angle between PA and the tangent of the current center (tangent to the trajectory of the center P, when the moving plane is moving to a new position)

ψ_B, ψ_C - defined similarly as ψ_A , PA, PB, PC are always taken as positive.

PC_A is treated as positive when A and C_A are on the same side of the current center P and negative when A and C_A are on opposite sides of the center P. The same is valid for PC_B and PC_C .

For an even better approximation of the desired trajectory, we can ask that the moving plane has four infinitely close positions. Then it is no longer possible to use any point of the movable plane for the installation of the bearing, since in general, it is not possible to achieve that the circle with the curve has contact of the fourth row at every point. Only those points of the movable plane, whose paths have a fixed value of curvature, for the moment of movement of interest, can be used as movable bearings (which at the same time belong to the coupler and members connected to it). The geometric location of points with a stationary curve is the "curve of circling points", and the geometric location of the points of the corresponding centers of curvature is the "curve of centering points". (These terms were used by German authors).

4. APPROACH TO PTO TRANSMISSION DESIGN

According to the Euler-Savary formula, the corresponding curvature center (formula 8) can be calculated for a given coupler point, or vice versa, for a given curvature center, the corresponding coupler point can also be found (formula 9). In this case, a turning circle must then be determined for the specific position of the transmission unit according to position and size. When different positions are to be compared regarding the ratio of the curvatures of coupler curves, and then this

can be done concerning the constant diameter of the turning circle d_w when certain positions of the transmission are plotted in the appropriate proportions.

Here we have that the Euler-Savary formula reflects legality, which can be represented as nomograms (construction tables). In doing so, one must start from the assumption that the turning circle is constant, as is the case with a small Cardan circle. The application of such nomograms for different transmission positions, different four-member transmissions with different turning circle diameters is simply a ratio issue. In this paper, we will not deal with the problem of nomograms, and accordingly we will give one example of designing a transmission without the use of construction tables.

4.1 Design of transmissions without the use of construction tables

Basically, the most common condition for designing a transmission will be that, for instance, a curve and perhaps a walker of a certain length should be practically applicable, due to existing standard parts or other design conditions.

The peculiarity of the Cardan transmission is that there is always the same image of the calculated transmission and the same ratios regarding the issue of rolling a small Cardan circle in a large one.

Here we will give *an example where we have the position of the tangent of the pole trajectory in parallel pole rays*. By comparing Figure 19a with Figure 19b, it is easy to see the transition from finding the tangent of the pole trajectory t at the finitely close pole (Figure 7.10a and Figure 7.10b) and at the infinitely distant pole (Figure 19b), when the angle of the full beam φ is replaced by one closed arc between its arms (Figure 19a), which at the infinitely distant pole becomes a straight line, i.e. the distance between parallel lines.

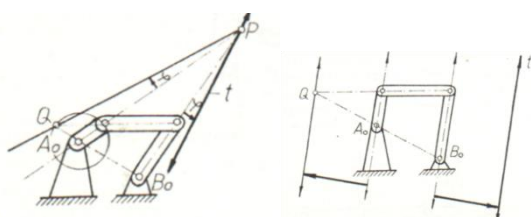

Figure 19. Position of the pole trajectory tangent at parallel pole rays

References:

- Bloh, Z. S. (1981). *Approximation synthesis of mechanisms*. Masgiz, Moscow,
 Dijkman, E. A. (1980). *Motion geometry of mechanism*. Cambridge university press, London-New York, Melbourne,
 Kornejcuk, N. P. (1976). *Extremal problems of approximation theory*. Moscow.
 Levitskii, N. I. (1981). *Theory of mechanisms and machines*. Moscow: Science.
 Norton, L. N. (2001). *Design of Machinery - An Introduction to the Synthesis and Analysis of Mechanisms and Machines*. New York: McGraw-Hill.
 Rusov, L. (1980). *Mechanics – kinematics*. Belgrade,

The relative pole Q is obtained as the intersection point of the midline of the coupler and the base (line through the support joints) (Figure 19b). At the distance of this relative pole from the curve, and measured from the walker in the opposite direction, the tangent of the trajectory pole t is drawn as a parallel line, at an infinitely distant pole at the moment of parallel center lines of the curve and the walker. The distance of the relative pole Q from the walker can be used, whereby the distance from the curve itself must be subtracted and applied in the opposite direction, in order to find the tangent of the pole trajectory t .

5. CONCLUSION

It can be concluded that this work provides a solid base of new information on the possibility of approximation of Cardan movement and quantitative magnitudes of deviations of various solutions from rectilinear paths. If we take into account all that is stated in the paper, it should be emphasized that when designing articulated four-member mechanisms with Cardan movement, it is necessary to check, among other things, the size of the error and whether it meets the technological requirements. If they happen to be unsatisfactory, then the deviation of the constructive positions of the plane between which there is a maximum constructive error should be undertaken. After that, the results again by analyzing and synthesizing the mechanisms should be checked. If we are not able to improve the accuracy of the movement in the proposed way, then we use one of the optimization techniques, with the application of nonlinear programming, which we have not dealt with in this paper, and may be a suggestion for further research. However, if the accuracy of the obtained movement meets the technological requirements of a particular application of the mechanism, then in that case the process of designing such mechanisms is interrupted. In particular, as a proposal for further research, it is suggested to develop a mathematical model for articulated four-member mechanisms, based on which all parameters of the articulated quadrilateral can be determined, and the coupler water point describes the desired trajectory or vice versa, for the observed approximation interval, since we have not dealt with the design of four-member mechanisms with the help of construction tables (nomograms) in this paper.

Uicker, J., Pennock, G., & Shigley, J. (2003). *Theory of Machines and Mechanisms*. Oxford University Press

Dragisa Micic

College of Applied Sciences,
Uzice,
Serbia
micicdr59@gmail.com

Zorica Lazic

College of Applied Sciences,
Uzice,
Serbia
zoricalazic29@gmail.com
